

**PIANTA FONDAZIONI**

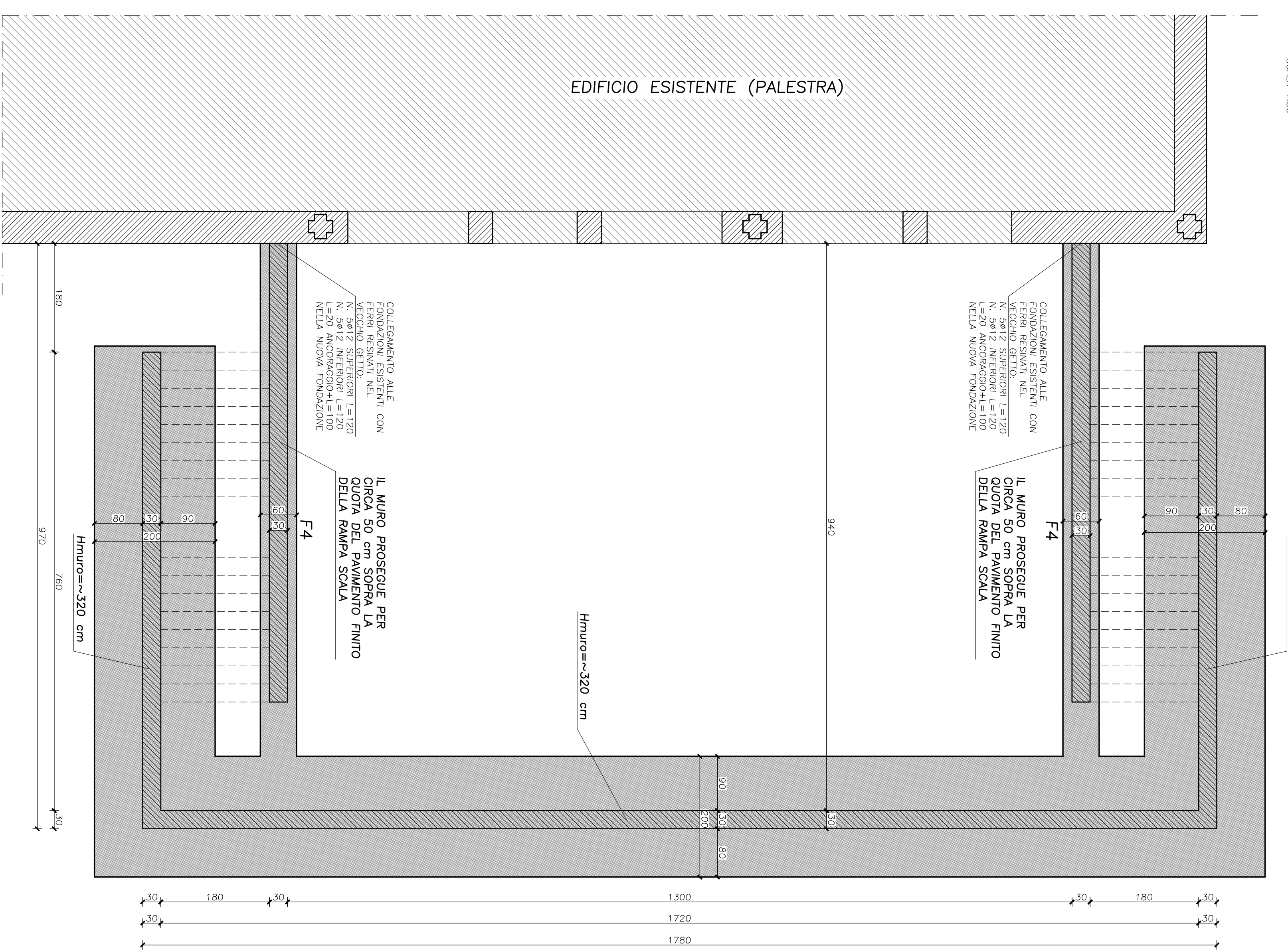

**PIANTA ELEVAZIONE**

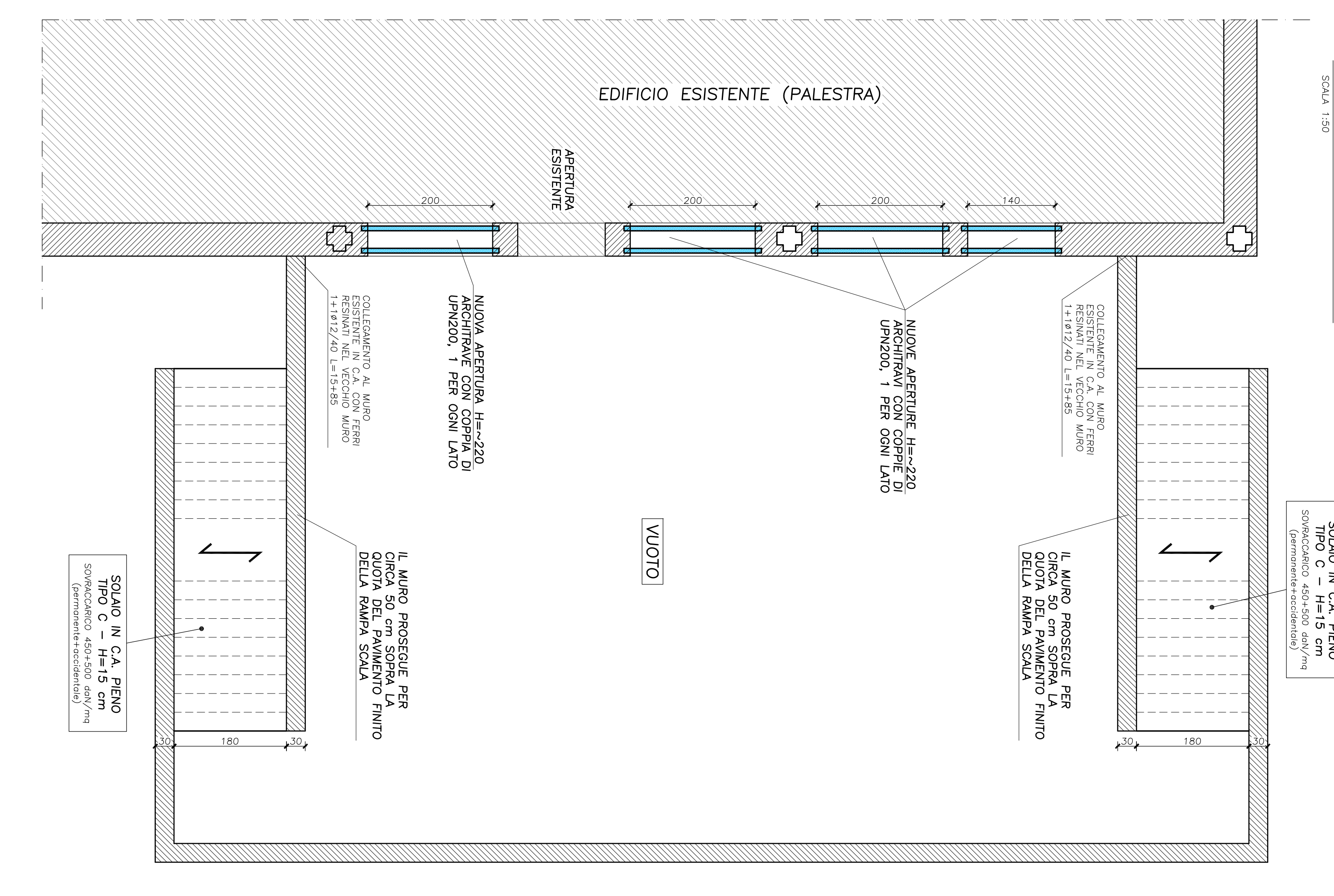

**MURO CONTENIMENTO NUOVA ZONA ESTERNA PALESTRA Hmax=320**

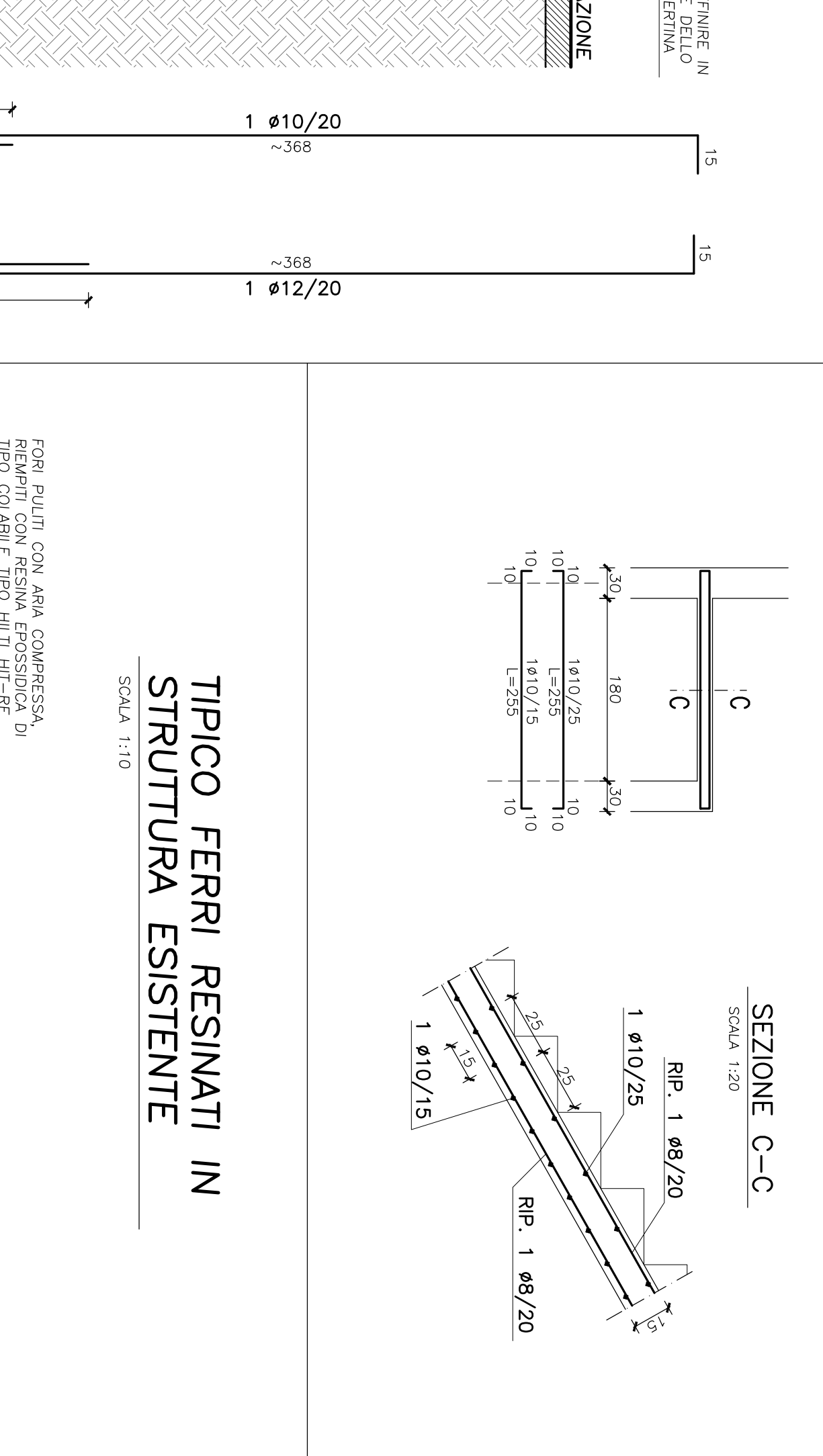
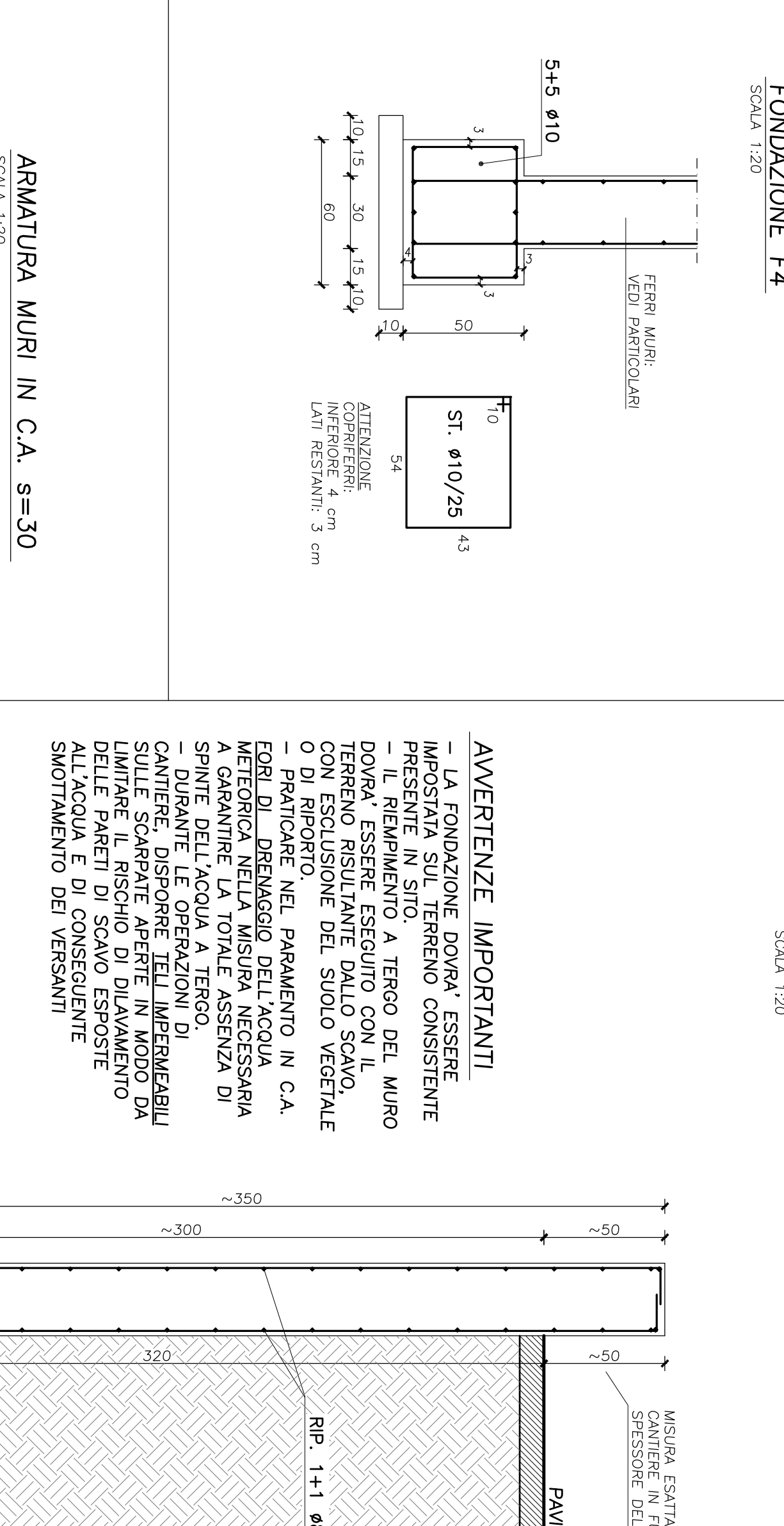

**AVVERTENZE IMPORTANTI**

LA FONDAZIONE DEVE ESSERE PRESENTE IN TUTTO IL PERIMETRO DEL MURINO. IL MURINO DEVE ESSERE REALIZZATO A TERZO DEL MURINO. IL MURINO DEVE ESSERE REALIZZATO IN CEMENTO ARMATO. IL MURINO DEVE ESSERE REALIZZATO IN CEMENTO ARMATO. IL MURINO DEVE ESSERE REALIZZATO IN CEMENTO ARMATO.

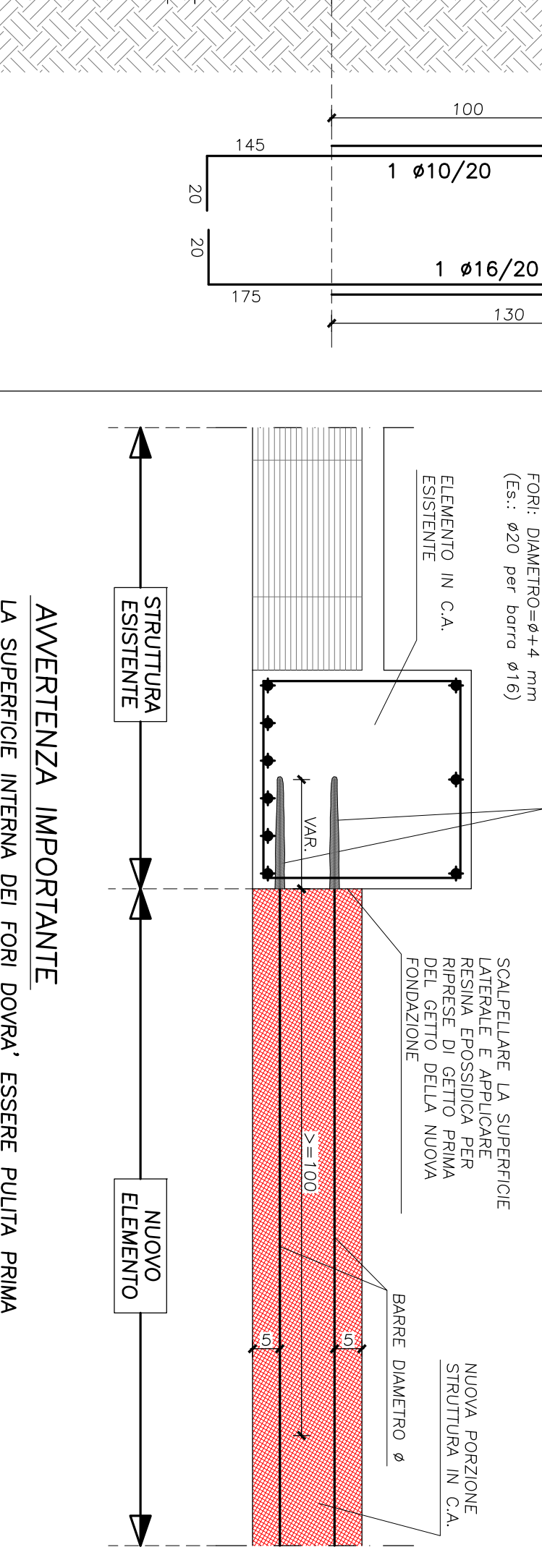
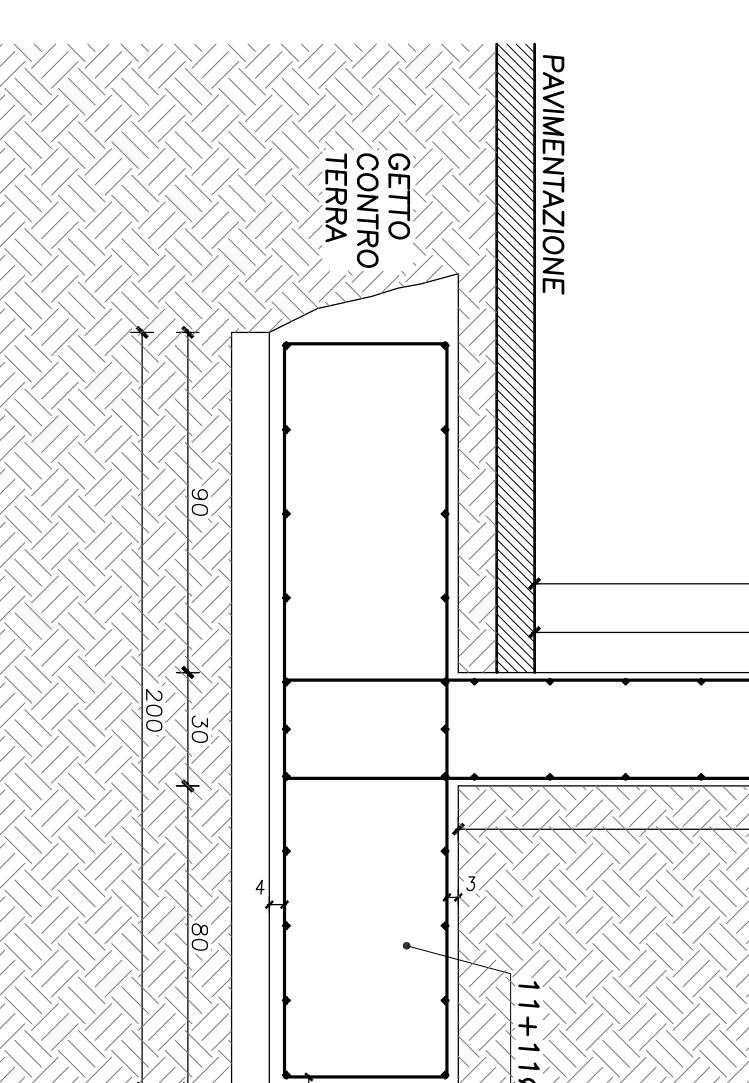

**SOLAI PIENO H=15 TIPO C NUOVE VIE DI FUGA PALESTRA**

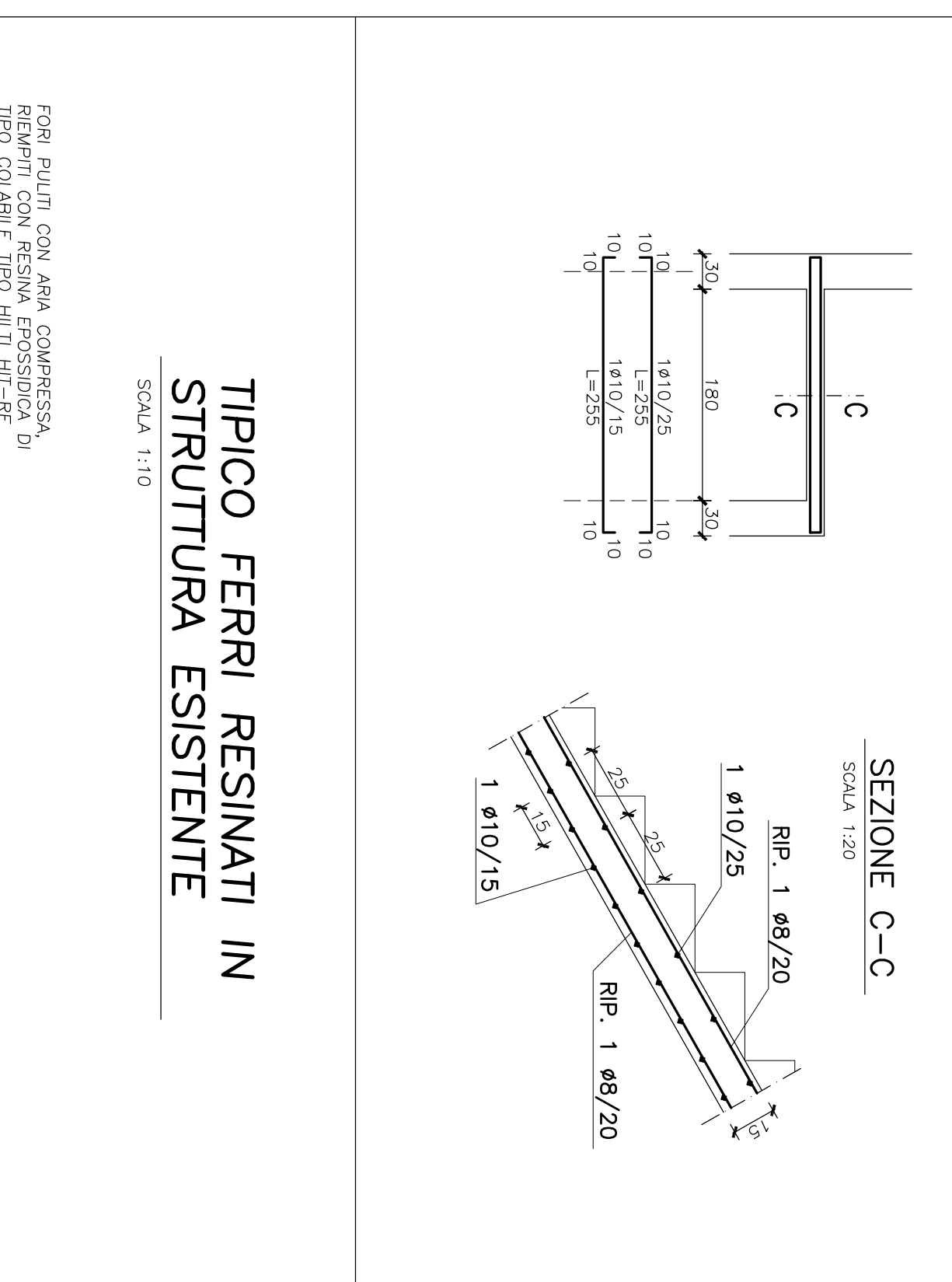

**TIPICO FERRI RESINATI IN STRUTTURA ESISTENTE**

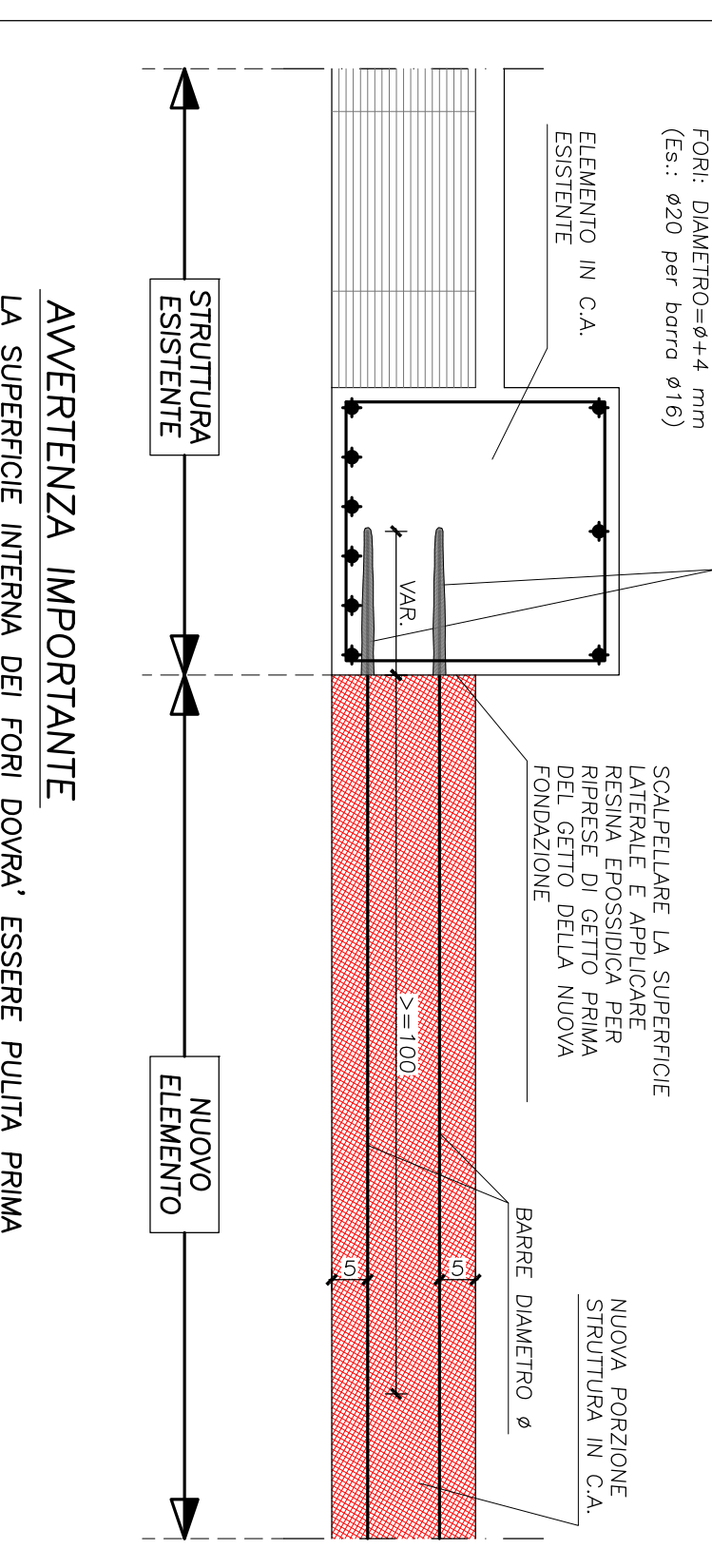

**AVVERTENZA IMPORTANTE**

LA SUPERFICIE INTERNA DEI FORI DEVE ESSERE PULITA PRIMA DELLA SOTTOPINTURA. LA SUPERFICIE DEVE ESSERE PULITA PRIMA DELLA SOTTOPINTURA. LA SUPERFICIE DEVE ESSERE PULITA PRIMA DELLA SOTTOPINTURA.

**MATERIALI**

<b>CEMENTAZIONE (G) (preparazione pronta)</b>	C15	C15	C15
<b>RESISTENZA CARATTERISTICA R<sub>c</sub> (MPa)</b>	15	15	15
<b>RESISTENZA CARATTERISTICA R<sub>s</sub> (MPa)</b>	30	30	30
<b>CLASSE ESPOSIZIONE (UNI 11104/2004)</b>	XS1	XS1	XS1
<b>CLASSE ESPOSIZIONE (UNI 11104/2004)</b>	XS2	XS2	XS2
<b>CLASSE ESPOSIZIONE (UNI 11104/2004)</b>	XS3	XS3	XS3
<b>CLASSE ESPOSIZIONE (UNI 11104/2004)</b>	XS4	XS4	XS4
<b>CLASSE ESPOSIZIONE (UNI 11104/2004)</b>	XS5	XS5	XS5
<b>CLASSE ESPOSIZIONE (UNI 11104/2004)</b>	XS6	XS6	XS6
<b>CLASSE ESPOSIZIONE (UNI 11104/2004)</b>	XS7	XS7	XS7
<b>CLASSE ESPOSIZIONE (UNI 11104/2004)</b>	XS8	XS8	XS8
<b>CLASSE ESPOSIZIONE (UNI 11104/2004)</b>	XS9	XS9	XS9
<b>CLASSE ESPOSIZIONE (UNI 11104/2004)</b>	XS10	XS10	XS10
<b>CLASSE ESPOSIZIONE (UNI 11104/2004)</b>	XS11	XS11	XS11
<b>CLASSE ESPOSIZIONE (UNI 11104/2004)</b>	XS12	XS12	XS12
<b>CLASSE ESPOSIZIONE (UNI 11104/2004)</b>	XS13	XS13	XS13
<b>CLASSE ESPOSIZIONE (UNI 11104/2004)</b>	XS14	XS14	XS14
<b>CLASSE ESPOSIZIONE (UNI 11104/2004)</b>	XS15	XS15	XS15
<b>CLASSE ESPOSIZIONE (UNI 11104/2004)</b>	XS16	XS16	XS16
<b>CLASSE ESPOSIZIONE (UNI 11104/2004)</b>	XS17	XS17	XS17
<b>CLASSE ESPOSIZIONE (UNI 11104/2004)</b>	XS18	XS18	XS18
<b>CLASSE ESPOSIZIONE (UNI 11104/2004)</b>	XS19	XS19	XS19
<b>CLASSE ESPOSIZIONE (UNI 11104/2004)</b>	XS20	XS20	XS20
<b>CLASSE ESPOSIZIONE (UNI 11104/2004)</b>	XS21	XS21	XS21
<b>CLASSE ESPOSIZIONE (UNI 11104/2004)</b>	XS22	XS22	XS22
<b>CLASSE ESPOSIZIONE (UNI 11104/2004)</b>	XS23	XS23	XS23
<b>CLASSE ESPOSIZIONE (UNI 11104/2004)</b>	XS24	XS24	XS24
<b>CLASSE ESPOSIZIONE (UNI 11104/2004)</b>	XS25	XS25	XS25
<b>CLASSE ESPOSIZIONE (UNI 11104/2004)</b>	XS26	XS26	XS26
<b>CLASSE ESPOSIZIONE (UNI 11104/2004)</b>	XS27	XS27	XS27
<b>CLASSE ESPOSIZIONE (UNI 11104/2004)</b>	XS28	XS28	XS28
<b>CLASSE ESPOSIZIONE (UNI 11104/2004)</b>	XS29	XS29	XS29
<b>CLASSE ESPOSIZIONE (UNI 11104/2004)</b>	XS30	XS30	XS30
<b>CLASSE ESPOSIZIONE (UNI 11104/2004)</b>	XS31	XS31	XS31
<b>CLASSE ESPOSIZIONE (UNI 11104/2004)</b>	XS32	XS32	XS32
<b>CLASSE ESPOSIZIONE (UNI 11104/2004)</b>	XS33	XS33	XS33
<b>CLASSE ESPOSIZIONE (UNI 11104/2004)</b>	XS34	XS34	XS34
<b>CLASSE ESPOSIZIONE (UNI 11104/2004)</b>	XS35	XS35	XS35
<b>CLASSE ESPOSIZIONE (UNI 11104/2004)</b>	XS36	XS36	XS36
<b>CLASSE ESPOSIZIONE (UNI 11104/2004)</b>	XS37	XS37	XS37
<b>CLASSE ESPOSIZIONE (UNI 11104/2004)</b>	XS38	XS38	XS38
<b>CLASSE ESPOSIZIONE (UNI 11104/2004)</b>	XS39	XS39	XS39
<b>CLASSE ESPOSIZIONE (UNI 11104/2004)</b>	XS40	XS40	XS40
<b>CLASSE ESPOSIZIONE (UNI 11104/2004)</b>	XS41	XS41	XS41
<b>CLASSE ESPOSIZIONE (UNI 11104/2004)</b>	XS42	XS42	XS42
<b>CLASSE ESPOSIZIONE (UNI 11104/2004)</b>	XS43	XS43	XS43
<b>CLASSE ESPOSIZIONE (UNI 11104/2004)</b>	XS44	XS44	XS44
<b>CLASSE ESPOSIZIONE (UNI 11104/2004)</b>	XS45	XS45	XS45
<b>CLASSE ESPOSIZIONE (UNI 11104/2004)</b>	XS46	XS46	XS46
<b>CLASSE ESPOSIZIONE (UNI 11104/2004)</b>	XS47	XS47	XS47
<b>CLASSE ESPOSIZIONE (UNI 11104/2004)</b>	XS48	XS48	XS48
<b>CLASSE ESPOSIZIONE (UNI 11104/2004)</b>	XS49	XS49	XS49
<b>CLASSE ESPOSIZIONE (UNI 11104/2004)</b>	XS50	XS50	XS50
<b>CLASSE ESPOSIZIONE (UNI 11104/2004)</b>	XS51	XS51	XS51
<b>CLASSE ESPOSIZIONE (UNI 11104/2004)</b>	XS52	XS52	XS52
<b>CLASSE ESPOSIZIONE (UNI 11104/2004)</b>	XS53	XS53	XS53
<b>CLASSE ESPOSIZIONE (UNI 11104/2004)</b>	XS54	XS54	XS54
<b>CLASSE ESPOSIZIONE (UNI 11104/2004)</b>	XS55	XS55	XS55
<b>CLASSE ESPOSIZIONE (UNI 11104/2004)</b>	XS56	XS56	XS56
<b>CLASSE ESPOSIZIONE (UNI 11104/2004)</b>	XS57	XS57	XS57
<b>CLASSE ESPOSIZIONE (UNI 11104/2004)</b>	XS58	XS58	XS58
<b>CLASSE ESPOSIZIONE (UNI 11104/2004)</b>	XS59	XS59	XS59
<b>CLASSE ESPOSIZIONE (UNI 11104/2004)</b>	XS60	XS60	XS60
<b>CLASSE ESPOSIZIONE (UNI 11104/2004)</b>	XS61	XS61	XS61
<b>CLASSE ESPOSIZIONE (UNI 11104/2004)</b>	XS62	XS62	XS62
<b>CLASSE ESPOSIZIONE (UNI 11104/2004)</b>	XS63	XS63	XS63
<b>CLASSE ESPOSIZIONE (UNI 11104/2004)</b>	XS64	XS64	XS64
<b>CLASSE ESPOSIZIONE (UNI 11104/2004)</b>	XS65	XS65	XS65
<b>CLASSE ESPOSIZIONE (UNI 11104/2004)</b>	XS66	XS66	XS66
<b>CLASSE ESPOSIZIONE (UNI 11104/2004)</b>	XS67	XS67	XS67
<b>CLASSE ESPOSIZIONE (UNI 11104/2004)</b>	XS68	XS68	XS68
<b>CLASSE ESPOSIZIONE (UNI 11104/2004)</b>	XS69	XS69	XS69
<b>CLASSE ESPOSIZIONE (UNI 11104/2004)</b>	XS70	XS70	XS70
<b>CLASSE ESPOSIZIONE (UNI 11104/2004)</b>	XS71	XS71	XS71
<b>CLASSE ESPOSIZIONE (UNI 11104/2004)</b>	XS72	XS72	XS72
<b>CLASSE ESPOSIZIONE (UNI 11104/2004)</b>	XS73	XS73	XS73
<b>CLASSE ESPOSIZIONE (UNI 11104/2004)</b>	XS74	XS74	XS74
<b>CLASSE ESPOSIZIONE (UNI 11104/2004)</b>	XS75	XS75	XS75
<b>CLASSE ESPOSIZIONE (UNI 11104/2004)</b>	XS76	XS76	XS76
<b>CLASSE ESPOSIZIONE (UNI 11104/2004)</b>	XS77	XS77	XS77
<b>CLASSE ESPOSIZIONE (UNI 11104/2004)</b>	XS78	XS78	XS78
<b>CLASSE ESPOSIZIONE (UNI 11104/2004)</b>	XS79	XS79	XS79
<b>CLASSE ESPOSIZIONE (UNI 11104/2004)</b>	XS80	XS80	XS80
<b>CLASSE ESPOSIZIONE (UNI 11104/2004)</b>	XS81	XS81	XS81
<b>CLASSE ESPOSIZIONE (UNI 11104/2004)</b>	XS82	XS82	XS82
<b>CLASSE ESPOSIZIONE (UNI 11104/2004)</b>	XS83	XS83	XS83
<b>CLASSE ESPOSIZIONE (UNI 11104/2004)</b>	XS84	XS84	XS84
<b>CLASSE ESPOSIZIONE (UNI 11104/2004)</b>	XS85	XS85	XS85
<b>CLASSE ESPOSIZIONE (UNI 11104/2004)</b>	XS86	XS86	XS86
<b>CLASSE ESPOSIZIONE (UNI 11104/2004)</b>	XS87	XS87	XS87
<b>CLASSE ESPOSIZIONE (UNI 11104/2004)</b>	XS88	XS88	XS88
<b>CLASSE ESPOSIZIONE (UNI 11104/2004)</b>	XS89	XS89	XS89
<b>CLASSE ESPOSIZIONE (UNI 11104/2004)</b>	XS90	XS90	XS90
<b>CLASSE ESPOSIZIONE (UNI 11104/2004)</b>	XS91	XS91	XS91
<b>CLASSE ESPOSIZIONE (UNI 11104/2004)</b>	XS92	XS92	XS92
<b>CLASSE ESPOSIZIONE (UNI 11104/2004)</b>	XS93	XS93	XS93
<b>CLASSE ESPOSIZIONE (UNI 11104/2004)</b>	XS94	XS94	XS94
<b>CLASSE ESPOSIZIONE (UNI 11104/2004)</b>	XS95	XS95	XS95
<b>CLASSE ESPOSIZIONE (UNI 11104/2004)</b>	XS96	XS96	XS96
<b>CLASSE ESPOSIZIONE (UNI 11104/2004)</b>	XS97	XS97	XS97
<b>CLASSE ESPOSIZIONE (UNI 11104/2004)</b>	XS98	XS98	XS98
<b>CLASSE ESPOSIZIONE (UNI 11104/2004)</b>	XS99	XS99	XS99
<b>CLASSE ESPOSIZIONE (UNI 11104/2004)</b>	XS100	XS100	XS100

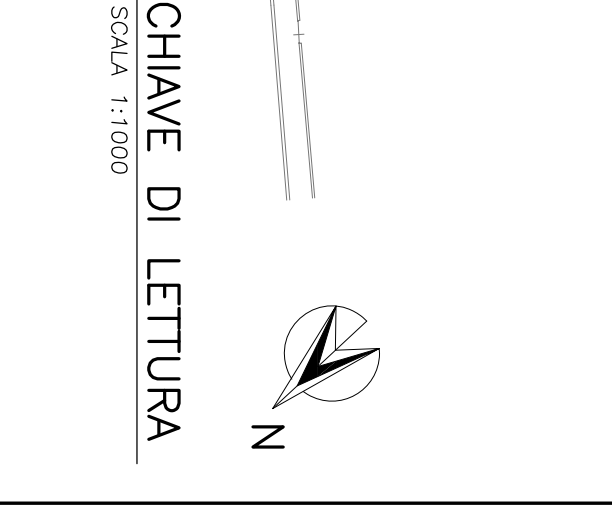
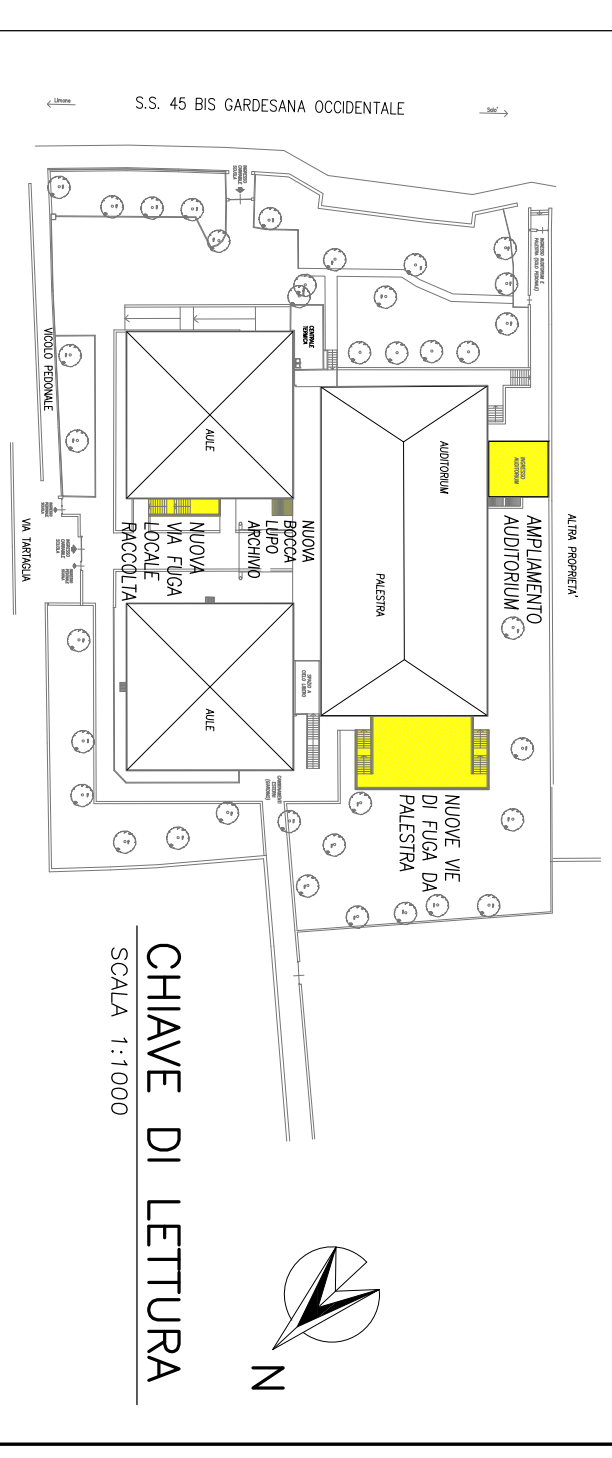

**COMITTEE**

**COMUNE DI TOSCOLANO MADERNO**  
 Provincia di Brescia

**SCUOLA SECONDARIA DI PRIMO GRADO DI TOSCOLANO MADERNO**  
 AMPLIAMENTO E MESSA A NORMA PREVENZIONE INCENDI

**P.1 - PROGETTO ESECUTIVO - 1° STRALCIO**

Progettista  
 Studio di Ingegneria Trevisani  
 Ing. Fabio Trevisani

Via E. Cini, 87 - 25021 Toscolano Maderno (BS)  
 Tel. 030/2300000 - Fax 030/2300001  
 www.trevisani.it - info@trevisani.it

Responsabile del procedimento:  
 Timoteo e firma del responsabile:

PROGETTO STRUTTURALE  
 Nuovo via di fuga e zona stationamento persone  
 all'esterno della palestra

Scala: 1:50 - 1:20 - 1:10

COMANDO: C154 - P1 ES 03 -

<b>CLASSE ESPOSIZIONE (UNI 11104/2004)</b>	XS1	XS1	XS1
<b>CLASSE ESPOSIZIONE (UNI 11104/2004)</b>	XS2	XS2	XS2
<b>CLASSE ESPOSIZIONE (UNI 11104/2004)</b>	XS3	XS3	XS3
<b>CLASSE ESPOSIZIONE (UNI 11104/2004)</b>	XS4	XS4	XS4
<b>CLASSE ESPOSIZIONE (UNI 11104/2004)</b>	XS5	XS5	XS5
<b>CLASSE ESPOSIZIONE (UNI 11104/2004)</b>	XS6	XS6	XS6
<b>CLASSE ESPOSIZIONE (UNI 11104/2004)</b>	XS7	XS7	XS7
<b>CLASSE ESPOSIZIONE (UNI 11104/2004)</b>	XS8	XS8	XS8
<b>CLASSE ESPOSIZIONE (UNI 11104/2004)</b>	XS9	XS9	XS9
<b>CLASSE ESPOSIZIONE (UNI 11104/2004)</b>	XS10	XS10	XS10
<b>CLASSE ESPOSIZIONE (UNI 11104/2004)</b>	XS11	XS11	XS11
<b>CLASSE ESPOSIZIONE (UNI 11104/2004)</b>	XS12	XS12	XS12
<b>CLASSE ESPOSIZIONE (UNI 11104/2004)</b>	XS13	XS13	XS13
<b>CLASSE ESPOSIZIONE (UNI 11104/2004)</b>	XS14	XS14	XS14
<b>CLASSE ESPOSIZIONE (UNI 11104/2004)</b>	XS15	XS15	XS15
<b>CLASSE ESPOSIZIONE (UNI 11104/2004)</b>	XS16	XS16	XS16
<b>CLASSE ESPOSIZIONE (UNI 11104/2004)</b>	XS17	XS17	XS17
<b>CLASSE ESPOSIZIONE (UNI 11104/2004)</b>	XS18	XS18	XS18
<b>CLASSE ESPOSIZIONE (UNI 11104/2004)</b>	XS19	XS19	XS19
<b>CLASSE ESPOSIZIONE (UNI 11104/2004)</b>	XS20	XS20	XS20
<b>CLASSE ESPOSIZIONE (UNI 11104/2004)</b>	XS21	XS21	XS21
<b>CLASSE ESPOSIZIONE (UNI 11104/2004)</b>	XS22	XS22	XS22
<b>CLASSE ESPOSIZIONE (UNI 11104/2004)</b>	XS23	XS23	XS23
<b>CLASSE ESPOSIZIONE (UNI 11104/2004)</b>	XS24	XS24	XS24
<b>CLASSE ESPOSIZIONE (UNI 11104/2004)</b>	XS25	XS25	XS25
<b>CLASSE ESPOSIZIONE (UNI 11104/2004)</b>	XS26	XS26	XS26
<b>CLASSE ESPOSIZIONE (UNI 11104/2004)</b>	XS27	XS27	XS27
<b>CLASSE ESPOSIZIONE (UNI 11104/2004)</b>	XS28	XS28	XS28
<b>CLASSE ESPOSIZIONE (UNI 11104/2004)</b>	XS29	XS29	XS29
<b>CLASSE ESPOSIZIONE (UNI 11104/2004)</b>	XS30	XS30	XS30
<b>CLASSE ESPOSIZIONE (UNI 11104/2004)</b>	XS31	XS31	XS31
<b>CLASSE ESPOSIZIONE (UNI 11104/2004)</b>	XS32	XS32	XS32
<b>CLASSE ESPOSIZIONE (UNI 11104/2004)</b>	XS33	XS33	XS33
<b>CLASSE ESPOSIZIONE (UNI 11104/2004)</b>	XS34	XS34	XS34
<b>CLASSE ESPOSIZIONE (UNI 11104/2004)</b>	XS35	XS35	XS35
<b>CLASSE ESPOSIZIONE (UNI 11104/2004)</b>	XS36	XS36	XS36
<b>CLASSE ESPOSIZIONE (UNI 11104/2004)</b>	XS37	XS37	XS37
<b>CLASSE ESPOSIZIONE (UNI 11104/2004)</b>	XS38	XS38	XS38
<b>CLASSE ESPOSIZIONE (UNI 11104/2004)</b>	XS39	XS39	XS39
<b>CLASSE ESPOSIZIONE (UNI 11104/2004)</b>	XS40	XS40	XS40
<b>CLASSE ESPOSIZIONE (UNI 11104/2004)</b>	XS41	XS41	XS41
<b>CLASSE ESPOSIZIONE (UNI 11104/2004)</b>	XS42	XS42	XS42
<b>CLASSE ESPOSIZIONE (UNI 11104/2004)</b>	XS43	XS43	XS43
<b>CLASSE ESPOSIZIONE (UNI 11104/2004)</b>	XS44	XS44	XS44
<b>CLASSE ESPOSIZIONE (UNI 11104/2004)</b>	XS45	XS45	XS45
<b>CLASSE ESPOSIZIONE (UNI 11104/2004)</b>	XS46	XS46	XS46
<b>CLASSE ESPOSIZIONE (UNI 11104/2004)</b>	XS47	XS47	XS47
<b>CLASSE ESPOSIZIONE (UNI 11104/2004)</b>	XS48	XS48	XS48
<b>CLASSE ESPOSIZIONE (UNI 11104/2004)</b>	XS49	XS49	XS49
<b>CLASSE ESPOSIZIONE (UNI 11104/2004)</b>	XS50	XS50	XS50
<b>CLASSE ESPOSIZIONE (UNI 11104/2004)</b>	XS51	XS51	XS51
<b>CLASSE ESPOSIZIONE (UNI 11104/2004)</b>	XS52	XS52	XS52
<b>CLASSE ESPOSIZIONE (UNI 11104/2004)</b>	XS53	XS53	XS53
<b>CLASSE ESPOSIZIONE (UNI 11104/2004)</b>	XS54	XS54	XS54
<b>CLASSE ESPOSIZIONE (UNI 11104/2004)</b>	XS55	XS55	XS55
<b>CLASSE ESPOSIZIONE (UNI 11104/2004)</b>	XS56	XS56	XS56
<b>CLASSE ESPOSIZIONE (UNI 11104/2004)</b>	XS57	XS57	XS57
<b>CLASSE ESPOSIZIONE (UNI 11104/2004)</b>	XS58	XS58	XS58
<b>CLASSE ESPOSIZIONE (UNI 11104/2004)</b>	XS59	XS59	XS59
<b>CLASSE ESPOSIZIONE (UNI 11104/2004)</b>	XS60	XS60	XS60
<b>CLASSE ESPOSIZIONE (UNI 11104/200</b>			